

THE EFFECTS OF OCCUPANCY, WWR, AND ORIENTATION ON ENERGY USE OF SCHOOL BUILDINGS IN GAZA, PALESTINE

Nagham Kh. Ali-Hasan

Ahmed R. Abdin

Department of Architecture
Faculty of Engineering, Cairo University

Khaled M.F. El-Deeb

Department of Architecture
Faculty of Fine Arts, Alexandria University

Abstract

Palestinian schools are designed due to the standards of ministry of education (MOE) in cooperation with UNESCO. Local school building designs are required to be more efficient climate-based and energy-conscious while maintaining indoor comfort levels. In addition, these schools suffer from classroom high occupancy density of up in the Gaza Strip to 40 students, while the target value is 30 students per classroom.

The paper aims to study the effect of occupancy, orientation, and window to wall ratio (WWR) factors on total energy consumption of school buildings in Gaza, Palestine and optimized the best for minimum energy use intensity. The method started by analyzing local climate and defined the reliable weather data for the software. A simulated model, that presented the common existing school building situation and located at Gaza strip, was developed. This model results was set as a reference value. The study investigated the effect of changing the occupancy density rates with considering international and local standards, orientation at the four basic directions, and WWR with regards to its impact on the amount of HVAC loads and lighting energy demand for the building. These investigations will optimize the best occupancy density and window size on energy consumption.

The results indicated that the increasing of occupancy had significant effect rather than opaque and glazing on energy consumption. It showed that density use in school buildings affect energy use about (27%) above the international standard, where the building envelope characteristics still determine a large part of the energy use in a school building (37.5%) for HVAC and lighting loads. East orientation has more effect on increasing energy consumption than other orientations as a result the amount of exposure to solar radiation for a longer period of the western façade due to the school schedule.

Keywords: Orientation, WWR, Building Envelope, Occupancy, Energy Use

المخلص

يتم تصميم المدارس في فلسطين تبعا وفقا لمعايير وزارة التربية والتعليم الفلسطينية وبالتعاون مع منظمة اليونسكو، ولكن نظرا لمحدودية الاراضي بالمنطقة تعاني الفصول الدراسية من نسبة إشغال عالية الكثافة تصل في قطاع غزة إلى 42 طالب بينما تقل هذه النسبة إلى 32 في مناطق الضفة الغربية، كما تعاني المدارس المحلية في فلسطين من التزايد المستمر في استخدام الطاقة نتيجة التزايد المستمر في استخدام نظم تكييف الهواء وزيادة ساعات تشغيل وحدات الاضاءة الصناعية على مدار اليوم الدراسي الناتج عن محدودية الضوء الطبيعي في داخل الفراغ.

تهدف الورقة البحثية إلى دراسة تأثير كل من عوامل إشغال الفراغ وتوجيه المبنى ونسبة فتحة الشباك إلى الحائط على كمية استهلاك الطاقة وتحسينها تم اختيار هذه العوامل الأكثر تأثيراً على كمية استهلاك الطاقة بمباني المدارس. تقوم الدراسة على تحليل المناخ والوضع القائم لمباني المدارس في مدينة غزة لتحديد نموذج لمبنى مدرسة قائم في مدينة خان يونس بقطاع غزة يمثل الحالة العامة القائمة للمدارس بالمنطقة واعتباره مرجع يمكن مقارنة نتائج تحسين الأداء عليه ، ثم دراسة تأثير العوامل الثلاثة على كمية استهلاك الطاقة بالمبنى من خلال دراسة تأثير تغيير نسبة الإشغال والتوجيه في الاتجاهات الأساسية الأربعة ومقارنتها بالمعايير العالمية، ودراسة تغيير نسبة فتحة الشباك للحائط وتأثيرها على كمية الإضاءة والاحمال الحرارية بالمبنى.

وتم تطبيق نموذج المحاكاة باستخدام برنامج *Designbuilder 2.4* لحساب استهلاك الطاقة السنوية والشهرية والاكنتساب والفقء الحراري خلال عناصر غلاف المبنى من السقف والحوائط الخارجية والفتحات على نموذج ثابت مفترض يحقق نسبة إشغال 0.8 طالب/م² ونسبة فتحات 25%. وأشارت النتائج إلى أن زيادة الازدحام بالفصل الدراسي يزيد من كمية الطاقة الداخلية وبالتالي يزيد أحمال التبريد بنسبة تصل إلى 27% من كمية الطاقة المستهلكة. ولا يزال خصائص غلاف المبنى يشكل عبء إضافي بنسبة 37% على أحمال التبريد والإضاءة. تعتبر الواجهة الشرقي هي الأكثر تأثيراً بالمناخ وذلك نتيجة تعرضها لكمية الإشعاع الشمسي لفترة أطول من الواجهة الغربية وذلك تبعاً للجدول المدرسي مما يتطلب الأخذ في الاعتبار معالجات الاظلال، نسبة فتحة الشباك 25% لا زالت تحقق أفضل أداء.

1. INTRODUCTION

Occupant, lighting, and equipment heat gain are the major sources of internal heat gains. For this reason, each source can be estimated separately and then summed to provide an estimate of the total energy consumption [1]. Changes in internal loads could affect the energy balance that would be used in an optimization based on feedback from an energy simulation.

Occupancy results in building heat gains due to both occupant metabolism and electric consumption in lights and equipment. The impacts due to building external envelope production had a small but significant environmental benefit as WWR increasing such as for daylighting. [2]. Increasing window area for better daylighting will increase heat transfer through envelope, since even the best performing glazing units do not possess that same thermal resistance of a sufficiently insulated opaque assembly. Depending on the window materials, the impact is reduced by 9–15% by change. Using daylighting to cut reliance on artificial light can reduce the electricity used to power the lighting, and additionally reduce cooling loads induced by the waste heat created by lighting fixtures [3].

Size and specifications according to (Tanner K., 2000) at his study for reviewed schools and achievement of students, was that the major problem may not be size, but density. His conclusion was that no one has completed definitive research on the relationship of distance among students and the amount of learning that takes place in defined spaces. One thing is for certain, crowding is a negative factor for student outcomes [4].

Three factors affect the classroom standard size such as the introduction of new technologies that has been brought requirements for more equipment in classrooms like computer. And, of course, new approaches to teaching and learning have had an impact on the added space to permit more flexible fit outs. In addition to, the new architecture designs of school building [5].

There are significant differences between countries, ranging from over 32 in Japan and Korea to 19 or below in Estonia, Iceland, Luxembourg, Slovenia and the United Kingdom. Standards however need to change over time. Factors such as the height and size of people, both of which have increased over the last century in many countries, have led to larger, wider seats and greater area requirements. [6]

The overall number of Palestinian schools operating on a double shift system was reduced from 86% in 2012 to 71% in 2013 and the class occupancy density was maintained at 38 students per classroom, down from 49 students per classroom in 2000, in spite of the population increase [7]. The government targets to reduce density to 30 students per meter square. Due to the increasing number of students, Many local schools have been forced to operate on double and triple shifts, leading to reduced learning time. It is estimated that an additional 260 schools (160 schools for the MOE and 100 for UNRWA) are needed to accommodate new students and to reduce the pressure on schools operating on a double and triple shifts [8].

Finding the right balance for a particular situation for internal and external heat gain would allow the designer to provide the solution that provides sufficient daylighting potential while maintaining a window to wall ratio that provides a good thermal performance with minimum energy consumption for heating, cooling and electrical lighting.

2. OBJECTIVE

This paper studied the effect of occupancy, orientation, and window to wall ratio (WWR) on total energy consumption through building envelope of school buildings in Gaza, Palestine. The questions are how drastically these possible changes in building orientation and WWR will alter the optimized solution, and what are the recommended occupancy density that can make to minimum energy consumption.

3. METHODOLOGY

The methodology adopted in this paper was carried out as follows:

1. The method starts by analyzing local climate and define the reliable weather data for the software.
2. The base case model were carried out on energy use intensity for Gaza City location (31° N, and 34°E) to calculate monthly and annual energy consumption and heat gain balance through the building envelope elements such as external walls, glazing, and roof. The base case model was assumed to be 0.8 student/m² occupancy, WWR 25%, and no fixed orientation.

The study investigated the effect the study of the effect of changing orientation at the four basic directions, the occupancy density rates with considering local standards, and WWR with regard to its impact on the amount of lighting and thermal loads of the building. These investigations will optimize the best occupancy and window size on energy consumption.

An existing school building was created by using *Designbuilder 2.4* software as full air-conditioned building. Its simulation results set as a reference value “common case” can be compared to the results of improving the performance. The comparative analysis have been done based on heat gain balance and total energy use by HVAC and artificial lighting with the common case simulation results which express the existing school buildings.

The output values collected from Energy plus were cooling, heating and lighting energy (electricity) required respectively. These values upon summation yield total electricity consumption which need to be minimized. It was referred to as Energy Use Intensity EUI.

$$EUI = E_{cool} + E_{heat} + E_{light}$$

4. GAZA CLIMATE ANALYSIS

Gaza has occupied a dividing position between the desert in the south and the Mediterranean climate in the North. The average daily mean temperature ranges from 25°C in summer to 13°C in winter. Daily relative humidity fluctuates between 65% in the daytime and 85% at night in the summer, and between 60% and 80 % respectively in winter [9]. Gaza Strip has a relatively high solar radiation. It has approximately 2861, annual sunshine -hour sunshine throughout the year. The daily average solar radiation on a horizontal surface is about 222W/m². [10] Gaza strip is divided into two climate zone [11], There was no available weather file data constructed on Energy Simulation Software.

Figure (1) Map of Palestinian Territories and Gaza Strip



Source: http://en.wikipedia.org/wiki/Gaza_Strip

The study used the weather data of the nearest city which was Al-Arish city in Egypt. Figure (2) shows the difference in mean temperatures for Gaza and Al Arish weather stations.

Table (1) shows comfort design strategies. Al-Arish comfort zone is less 15% than Gaza and need for more cooling design. Despite Gaza zone required considering on shading strategies. From the weather data analysis of Al Arish, cooling hours was higher than the comfort zone in 44% the occupied period while it was lower than the comfort levels in 36%. This indicated that the building envelope design and composition should be thoroughly considered to mitigate the effect of external climatic conditions.

Table (1) Climate characteristics for Gaza and Al-Arish zone
Source: [11], [12]

Zone	Wind velocity m/s	Extreme temperature (°C)		Relative Humidity (%)	
		Max	Min	Max	Min
Gaza	2.8	31	9	65	49
Al-Arish	3	32	5	72	50

Figure (2) Average mean temperature for Gaza and Al-Arish stations

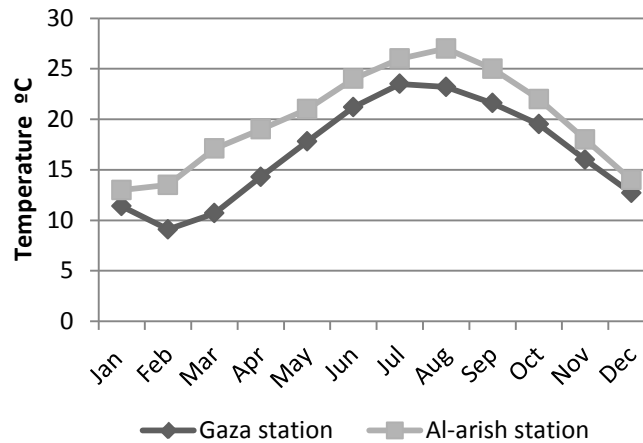

4.1. The Common Reference Value

Palestinian school buildings follow a prototype design with single loaded corridors serving and spaces like classrooms, labs, library or administration. The simulations applied at monthly and annual energy consumption on a model that presents the common school building situation in Gaza is located in Khan-Younis, Gaza strip. The common case school model properties, as in Table (2), is a three story primary school building constructed in 2005. The total floor area is about 1245.5 m² with 31 total classrooms. The building oriented at south east. The building material is hollow cement block covered with plaster layer. The windows all use a single 6mm clear glass with a U-value 6.17 W/m².k and Aluminium frame with non-thermal breaks as commonly used in local practice. The building workdays schedule input starts from 7:00am to 16:30 am from September to 31st of May. The school works from 7:00am to 14:00 am at 1st June to 31st August, Friday is the weekend. The study proposed that this school building model is a stand-alone building without overshadow from any adjacent buildings. Therefore, there is no consideration for any shading devices and site unless the windows on the inner façade are shaded by corridor.

Simulation results showed that the total EUI_{MOE} = 191 kWh/m², of which 96% were used for cooling and only 4% for lighting. It was clear through monthly results that energy for cooling increased at the period from April to October. It was observed that internal heat gain from occupancy was larger than heat gains from external loads by about 9%. This result indicated that the occupancy is a main parameter that had to be considered.

Table (2) The common case model properties

Parameter	Values	U value (W/m ² -K)
Roof	4mm Single ply plastic bitumen	0.64
	11cm Foam concrete	
	0.25m Reinforced concrete slab	
	0.02m Cement plaster	
Wall	15cm Hollow cement block	2.74
	25cm Cement plaster (external & internal)	
Glazing	Single glazed 6mm, VLT: 0.88%, SHGC: 0.81	5.7
Illuminance task	300 lux	
HVAC	Heating set point 20	
	Cooling set point 24	

Figure (3) the common school model isometric

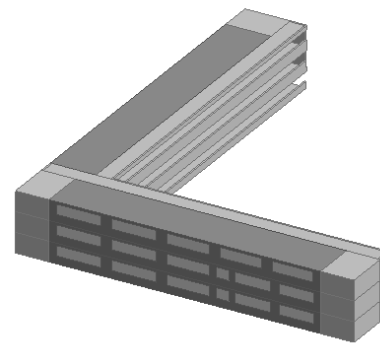

Total floor area= 1245.5m²

Figure (4) The simulation results for the common case

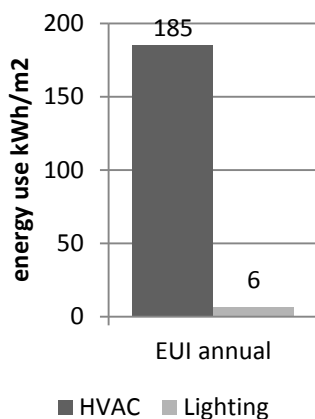

Monthly HVAC and lighting Loads of the common-case

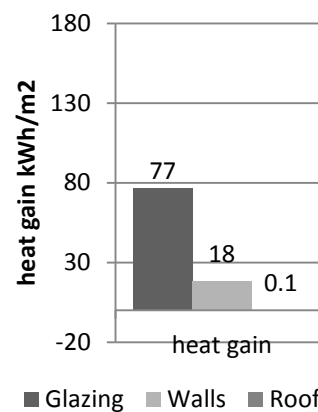

Monthly heat gain from windows, roof and external walls of the common-case

4.2. Setting the Base Case

The base case was assumed to be a rectangular block of group of 7 classrooms with three floors height with WWR 25% and 0.84 occupancy. The building model orientation was not fixed. The investigated variables are shown on Table 3. This included building orientation, occupancy density, and window-to-wall ratio (WWR). Internal loads from different occupancy and artificial lighting at 300lux only were accounted for. First, alternatives of each single parameter were tested, and then based on the results; the optimum performing alternatives of all tested parameters were combined, applied on the model and simulated. This represented the suggested optimized best practice case.

Figure (4) The base case model

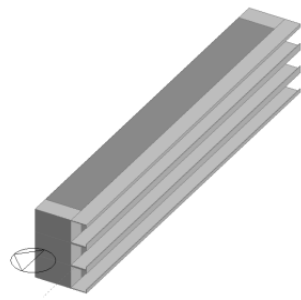

Floor Area : 336m²
 WWR: 25%
 Flat roof 0.64 W/m².K
 External walls 2.74 W/m².K
 Windows 5.7 W/m².K
 Lighting 300 lux
 Occupancy 0.8 student/m²
 Split & mech. Ventilation

Table (3) Investigated variables for the base case

Parameter	Rage of value
Building orientation	N, E, S, and W
Occupancy	0, 0.4, 0.6, 0.8, and 1.0student/m ² .
Window-to-wall ratios	15%, 20%, 25%, 30% and 35%, the ratio of glazed area to both inside and outside facing wall.

5. SIMULATION RESULTS AND ANALYSIS

5.1. Effect of Building orientation on energy use

Firstly, the simulation runs on no occupancy “No internal gain” for 4 basic orientations in order to understand the envelope performance without internal loads. The changes in annual EUI for heating and cooling (HVAC) loads and artificial lighting have been illustrated in Figure (5) were 2%, 18%, 20%, and 12% significantly. The chart showed that the south-orientation had the maximum loads and its external heat gain from envelope element reduced from 33% to 13% when the school was occupied. The east orientation was still sensitive for solar gain. The study becomes quite evident that orientations might have significant effect for external loads on building. For improvement the occupancy heat gain loads should be considered.

Figure (5) The annual heat gain loads for walls, window, and roof, at occupancy 0.0 and 0.84 student/m²

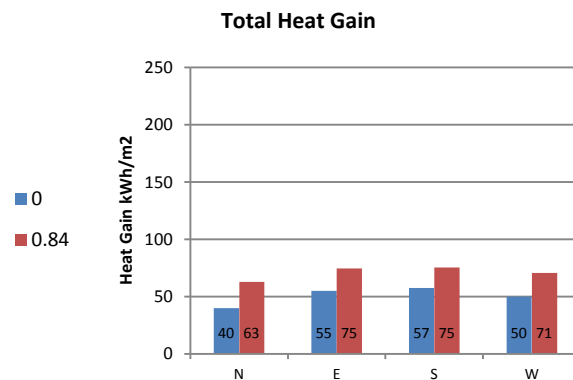
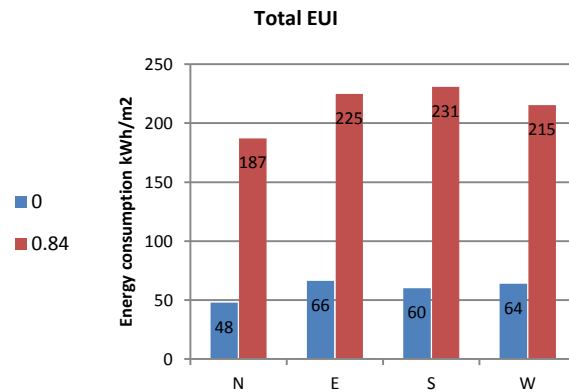

Figure (6) The annual EUI for heating, cooling and lighting loads, at WWR 25% and occupancy 0.0 and 0.84 student/m²



5.2. Effect of Occupancy on energy use:

The international standard occupancy for school recommended by UNESCO, (2004) for different countries it ranges 30 to 36 students. The local government standards specify 30 students per classroom as a target density [13]. The study suggested that the investigated variables are 0, 0.4, 0.6, 0.8, and 1.0 student/m² densities. Internal heat gain per student equal 2.8kWh/m² where the classroom size is 48m², the external heat gain from building envelope was 37.5kWh/m², the correlation is linear.

From results, The energy use per student decreased to 49% when classroom density increased to 48 students per class (1.0 student/m²) while it decreased to 22% when the classroom density is 30 student per class (0.6 student/m²). Saving of energy consumption reduced to more than a half when occupant density is at the minimum case 20 student per class (0.4 student/m²). And the EUI saving per meter square was about (26%) below the base case and 32% common case. The effect of heat gain of the envelope may be neglected by increasing the internal heat gain at high densities.

The effect of occupant characteristics and densities might be larger than expected. Therefore, The study suggested occupancy 0.6 student/m², optimum density recommended by UNISCO, is recommended for Gaza school.

Table (4) Energy use for different occupancy densities

Occupancy Student/m ²	Cooling kWh	Heating kWh	Lighting kWh	Total Energy Use kWh	Energy Use kWh /student
0.4	119869	507	4253	124629	297
0.6	155919	272	4253	160443	297
0.84	199670	207	4253	204130	243
1	228729	175	4253	233157	231

Figure (7) Total annual energy use, at WWR 25%, and different occupancy densities for East orientation

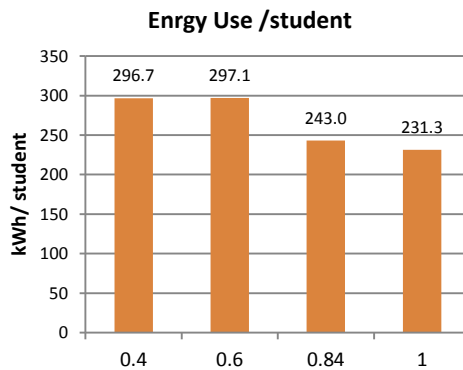

5.3. Effect of WWR on energy use:

The effect of increasing WWR on HVAC and artificial lighting has been shown on Figure (8). HVAC energy loads increase with increasing WWR, on the other hand the trend for artificial lighting energy is just opposite, it decreases with increasing WWR. Thus, the overall impact of WWR on total energy consumption can be seen on Figure (8). The curve of lighting begin to slight smooth at WWR 30% .

Figure (8) Total annual HVAC and lighting Loads, Gaza at different WWR

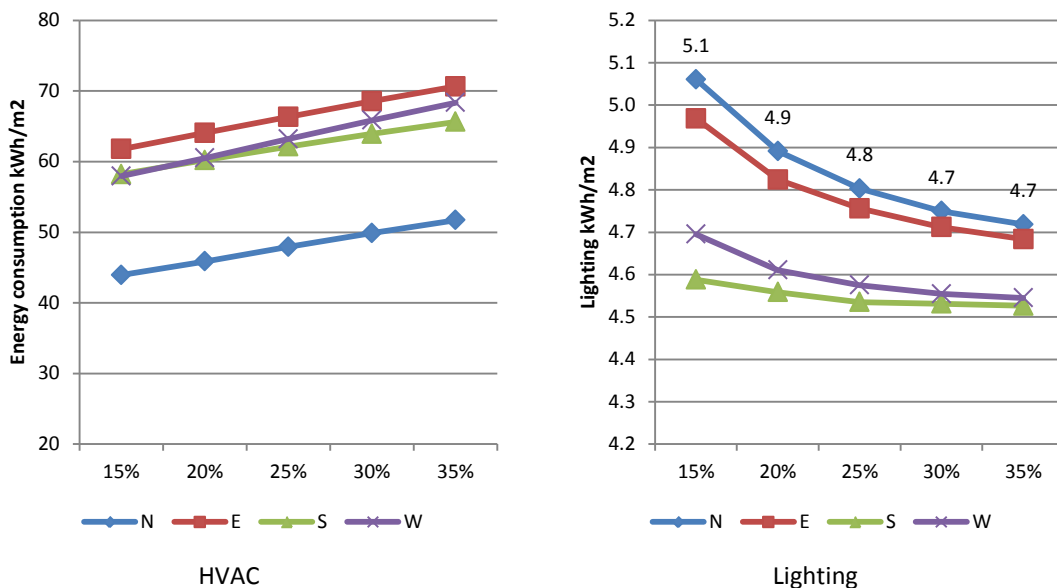

The heat exchange would be increased for the heat transfer coefficient of window for single glazed being larger than that of wall. Heat gains increased 18% as the WWR increases from 15% to 25% and the cooling loads reached 7%.

On the other hand, the artificial lighting consumption will decrease about 6.25% at WWR 15% as WWR increases to 25% as illustrated on Figure (8). These two opposing facts bring out that an optimum WWR is reached where the total electricity consumption is minimized. The heat gain loads increased.

6. CONCLUSION

The results showed that east and south orientations had more sensitive effect on increasing energy consumption than the other orientations, that because the direct sun radiation along the school schedule from 7:00 to 16:30. Therefore, the building orientation should be considered according to solar path.

From the results, the study recommended for using 0.6 student/m² occupancy to be optimized, as it seems to be reasonable for Gaza school buildings because the limited area for building new schools. For saving new classroom, The school building can extended vertically but the study will done on the aspect ratio of building envelope.

The applied WWR 25% still best for balance between daylight and HVAC loads. Increasing of occupancy was more effect than opaque and glazing improvements on energy consumption.

When comparing the results with the common case as actual building (191kWh/m²), the saving of energy was 27%. This study showed that occupant density use in school buildings affect energy use therefore, the effect of occupant characteristics and school schedule might be larger than expected. But building envelope characteristics still determine a large part of the energy use in a school building (37.5%). But the effect of heat gain exchange from the building envelope may be neglected by increasing the internal heat gain at high densities. This fact may lead to no sensitive improvement for building thermal characteristics for saving energy consumption.

Glazing type and window shading devices even though internal or external for air conditioned building is the major considered factor for minimizing solar heat gain with the large window size. This is should take into account the visual comfort and daylighting.

References

- (1) Glassman, E. J. and Reinhart C. (2013), Facade Optimization Using Parametric Design And Future Climate Scenarios, 13th Conference of International Building Performance Simulation Association, Chambéry, France, August, pages: 26-28
- (2) Vital Sign (2014), Building Balance Point, Level 1: Introduction to First Order Principles, Vital signs curriculum materials project, <http://web.utk.edu/~archinfo/EcoDesign/546c/EXERCISES/EX4BalancePt/BalPtDocs/BPnum2.pdf>, Inter website at: 23th May
- (3) Su, X. and Zhang, X. (2010), Environmental Performance Optimization Of Window-Wall Ratio For Different Window Type In Hot Summer and Cold Winter Zone In China Based On Life Cycle Assessment, *Energy and Buildings Journal*, Volume 42, Issue 2, February, Pages 198–202. <http://www.sciencedirect.com/science/article/pii/S0378778809002060>

- (4) Tanner, C. K. (2000), Minimum Classroom Size and Number of Students Per Classroom, The University of Georgia, School Design and Planning Laboratory, Facilities Planning, Design, & Management at UGA, April, 2000
- (5) <http://sdpl.coe.uga.edu/research/territoriality.html>
- (6) Raines, K. (2012), Performance Modelling for a Sustainable Master Plan, 5th National Conference of IBPSA-USA, Madison, Wisconsin, August, pages:1-3
- (7) Al-Tamimi, N. A. (2011), The Effects of Orientation, Ventilation, and Varied WWR on the Thermal Performance of Residential Rooms in the Tropics, *Journal of Sustainable Development* Vol. 4, No. 2; April 142-149
- (8) PCBS (2013), Palestine in Figures, The Palestinian Central Bureau of Statistics, Ramallah, Palestine, March 2014, http://www.pcbs.gov.ps/Portals/_PCBS/Downloads/book2040.pdf
- (9) OECD (2010), The impact of school design on academic achievement in the Palestinian territories: an empirical study, CELE Exchange, May 2010 OECD (2010), ISSN 2072-7925
- (10) Badawy, U. (2014), Climate Conditions Impact on the Architectural Design in Palestine. *European Journal of Academic Essays*, pages:1-7, www.euroessays.org
- (11) HPCR (2010), Assessing Human Security Needs in the Gaza Strip, Working paper No.1, Population Projections for Socioeconomic Development in Gaza Strip, Massachusetts, USA, Page: 7
- (12) Energy Efficient Building Code (2004), Ministry of Local Government
- (13) Al-Arish weather file http://apps1.eere.energy.gov/buildings/energyplus/weatherdata_about.cfm
- (14) MOE (2003), Future school in Palestine, a manual for designing schools the ministry of education, The Ministry of Education, UNESCO, Ramallah